

Design RDA ... ESO-...-0...

Hub with keyway

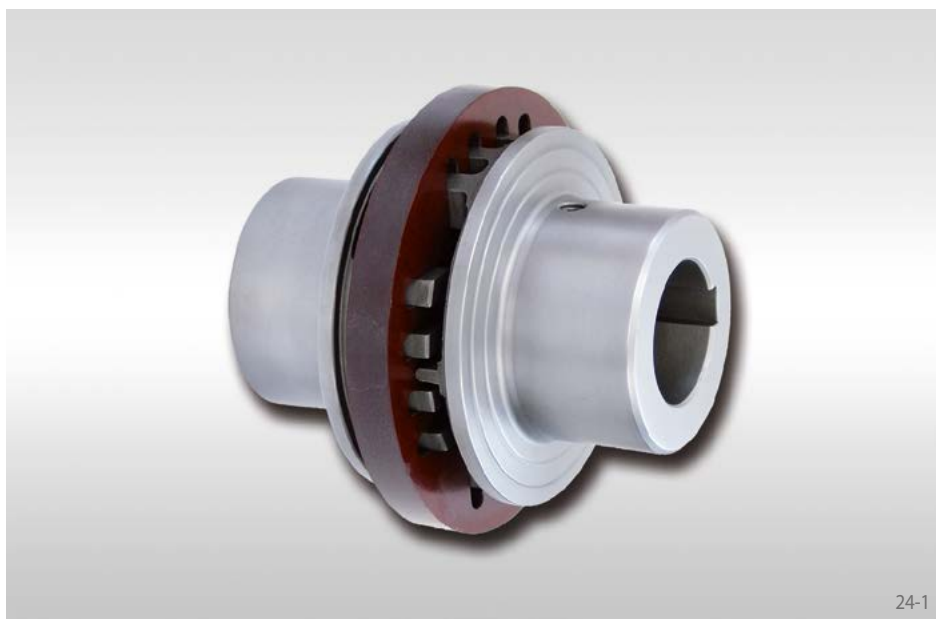

24-1

Features

- Compact design
- Simple robust design
- Electrical insulation
- No stick-slip effect
- Large radial shaft misalignment permissible
- Torsionally rigid
- Minimal restoring forces to adjacent machine parts
- Typical applications: Printing machines, machine tools

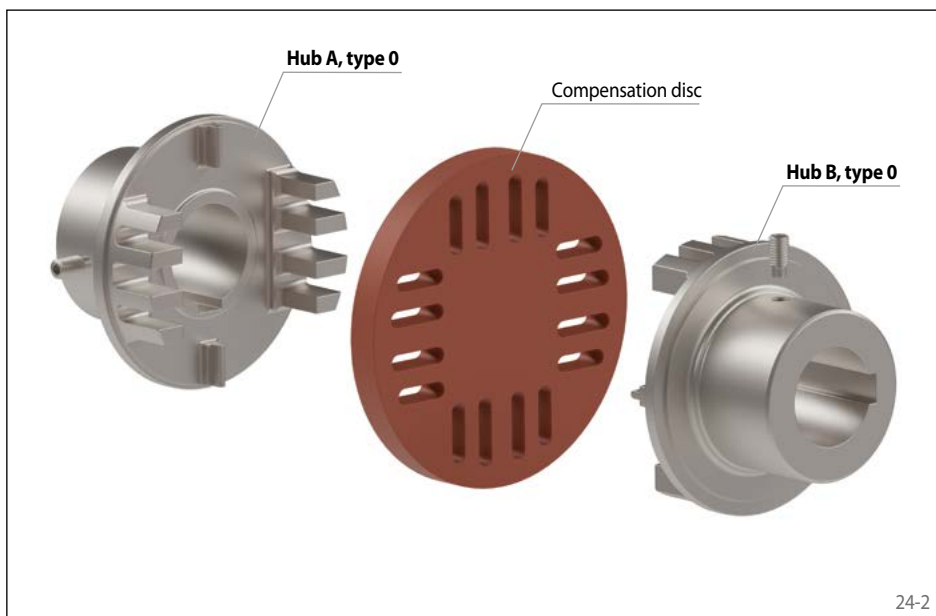

24-2

Order example

	Code
Coupling design	RDA
Coupling size	0012
Type	ESO
Material of the hub:	
• Steel	STA
• Nodular cast iron	GJS
Hub A, type:	0
• 0, standard	
Hub A, design:	
• finish bored with keyway	FB
• roughbored	VA
Bore diameter hub A	010
Hub B, type:	0
• 0, standard	
Hub B, design:	
• finish bored with keyway	FB
• roughbored	VA
Bore diameter hub B	015
Material of the compensation disc:	
• HGW 2082 in accordance with DIN 7735	HG82
• PARA-GF60*	PAGF

RDA 0012 ESO-GJS-0FB010-0FB015-HG82

*RDA 0010 ESO only

Design RDA ... ESO-...-0...

Hub with keyway

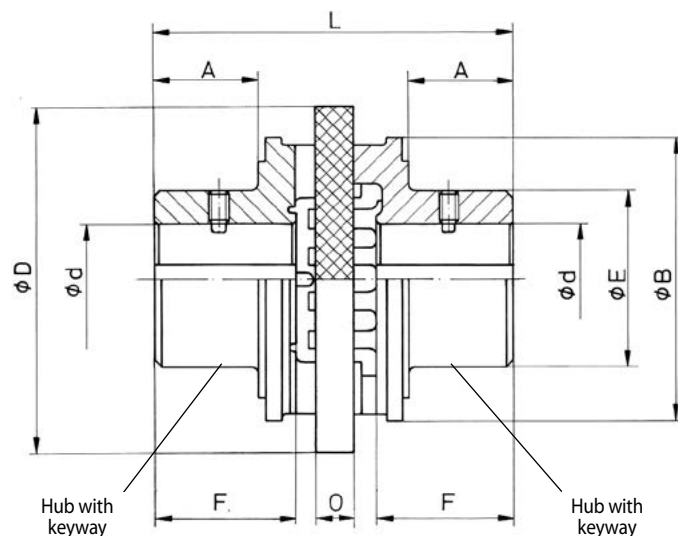

25-1

Coupling size	Material of the hub		Max. torque T_{Kmax} Nm	Max. speed n_{max} min ⁻¹	Moment of inertia J_k kgm ²	Max. misalignments**		Pilot bore d mm	Finish bore d		A mm	B mm	D mm	E mm	F*** mm	L mm	O mm	Weight with rough bore kg
	Steel	Nodular cast iron				Axial	Radial		min. mm	max. mm								
	STA	GJS				+/- mm	mm											
0010*	x	-	2	13000	0,0001	0,75	0,50	4,3	5	15	-	-	32	26	13	35	6	0,10
0012	x	-	4	10500	0,0002	0,75	0,60	5	6	18	-	-	40	32	16	42	4	0,20
0016	x	-	8	8400	0,0003	0,75	0,80	7	8	25	-	-	50	40	18,5	51	6	0,38
0020	x	-	16	6800	0,0004	1,00	1,00	9	10	30	-	-	63	50	25	64	6	0,78
0027	x	-	32	5350	0,0008	1,25	1,35	11	12	40	-	-	80	65	32	85	8	1,70
0035	-	x	85	4100	0,0013	1,50	1,75	15	16	35	33	90	110	53	42	112	12	1,90
0042	-	x	190	3400	0,0039	1,50	2,10	19	20	42	41	110	135	66	53	136	14	3,70
0050	-	x	500	2670	0,0097	2,00	2,50	29	30	50	51	135	160	85	62	159	16	6,30
0070	-	x	1000	2140	0,0268	2,00	3,50	33	34	70	65	163	200	104	79	200	20	12,10
0090	-	x	2000	1700	0,1110	2,50	4,50	48	50	90	81	202	250	150	100	247	25	28,90
0110	-	x	4000	1350	0,2911	4,00	5,50	58	60	110	101	254	315	175	124	312	32	50,90
0140	-	x	8000	1050	0,9767	4,50	7,00	72	75	140	130	330	400	216	160	402	40	104,00

For finish bores, please specify bore diameter hub A and hub B. Tolerance of finish bores H7. Keyways in accordance with DIN 6885, sheet 1. Keyway tolerance P9.

* Material of compensation disc PARA-GF60

** max. angular displacement 3°.

*** The hub length F can be shortened, which would change the dimensions A, C and L accordingly.

Elastomer element	Material	Temperature range °C	Colour
HGW 2082	Cotton fabric-phenolic	up to +100	red