

Clamping Systems RTM 134.1 and RTM 134.2

for complete torque motors

for mounting and centring complete torque motors on shafts or hollow shafts

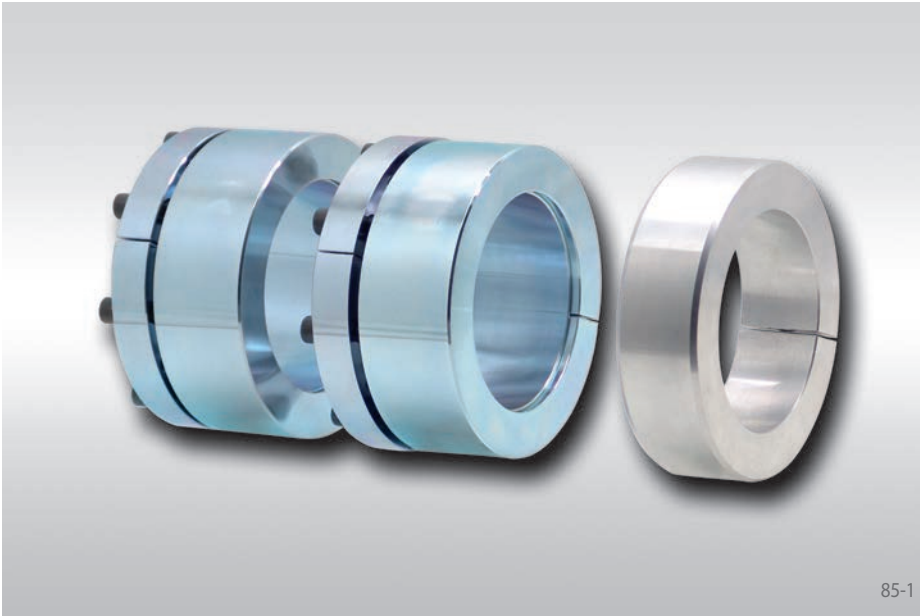

85-1

Features

- Provides a mechanical connection and centring between rotor and machine shaft. Support is provided by additional centring ring
- Backlash free, torsion-proof transmission of torque generated by the torque motor
- High true running accuracy
- Optimally configured contact pressure prevents undesirable deformation of the hollow rotor shaft of the torque motor and the hollow machine shaft
- Taper Collet galvanized and blue-chromed to prevent fretting corrosion
- Easily removable Cone Clamping Elements, even after long periods of operation
- Cone Clamping Elements can be mounted from the B-side of the torque motor

Configuration

Depending on the amount of torque to be transmitted between the machine shaft or hollow shaft and the torque motor, either one or two Cone Clamping Elements are used for torque transmission and a centring ring as a second support point are used. The Cone Clamping Elements have been developed in keeping the specific requirements of torque motors. The taper angle is designed in such a way that the Cone Clamping Elements can be removed easily, even after extended periods of operation, and no undesirable contact pressures cause indentations on the torque motor rotor shaft, which is ordinarily a thin-walled element.

The torque motor manufacturer should be consulted prior to installing this Clamping System. Therefore, we request submission of your enquiry in the event that a Clamping System this kind is considered suitable for your application.

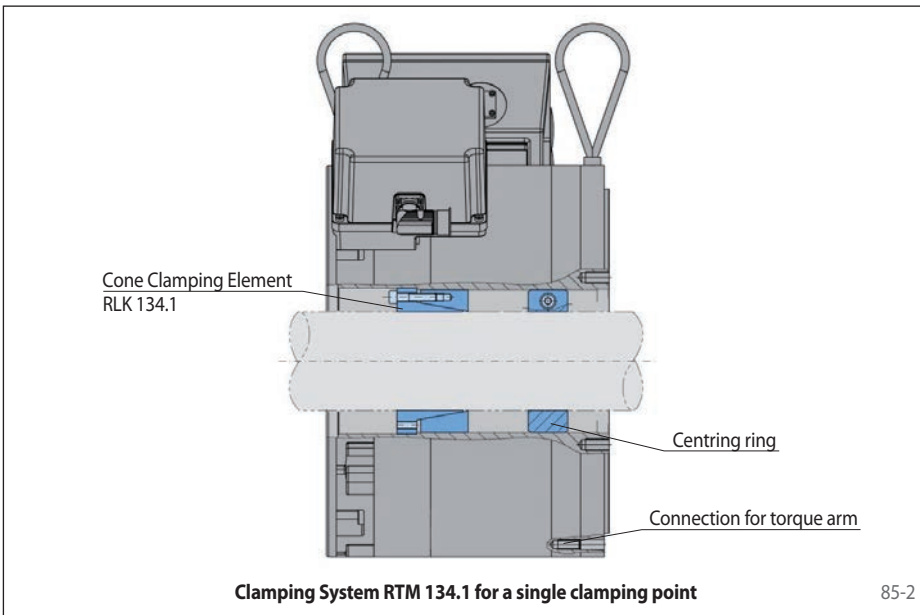

Clamping System RTM 134.1 for a single clamping point

85-2

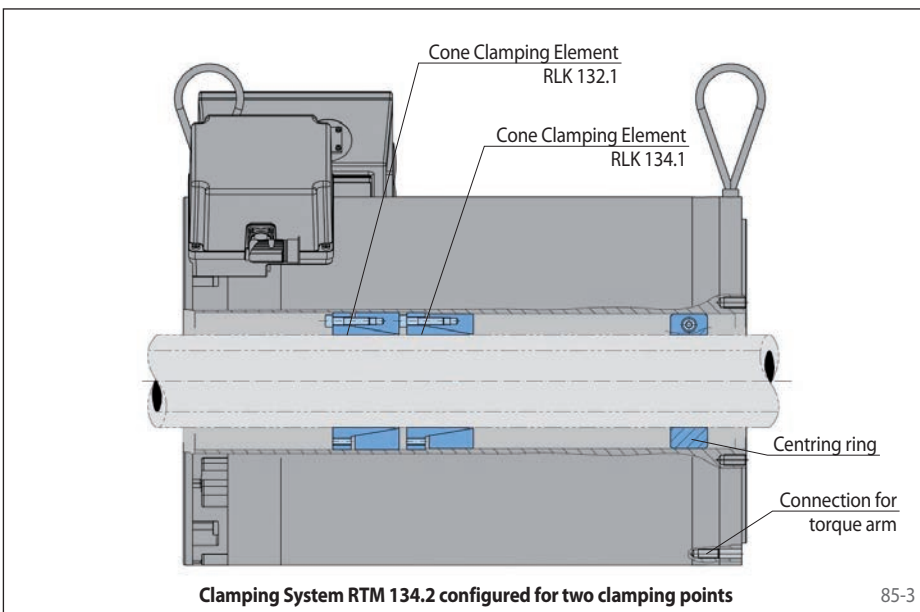

Clamping System RTM 134.2 configured for two clamping points

85-3